

ISBN 978-0-626-25101-7

NRS 097-2-1:2010

Edition 1

GRID INTERCONNECTION OF EMBEDDED GENERATION

Part 2: Small-scale embedded generation

Section 1: Utility interface

This document does not have the status of a South African National Standard.



This specification is issued by
the Standardization Section, Eskom,
on behalf of the
User Group given in the foreword.

Table of changes

Change No.	Date	Text affected

Correspondence to be directed to

The NRS Projects Manager
The Standardization Section
Industry Association Resource Centre
Eskom
Private Bag X13
Halfway House 1685

Telephone : (011) 651 6832
Fax : (011) 651 6827
E-mail : nrs@eskom.co.za
Website : <http://www.nrs.eskom.co.za>

Printed and electronic copies obtainable from

The SABS Standards Division
Private Bag X191
Pretoria 0001

Telephone : (012) 428-7911
Fax : (012) 344-1568
E-mail : sales@sabs.co.za
Website : <http://www.sabs.co.za>

COPYRIGHT RESERVED

Printed in the Republic of South Africa
by the SABS Standards Division
1 Dr Lategan Road, Groenkloof, Pretoria

Foreword

This section of NRS 097-2 was prepared on behalf of the Electricity Suppliers Liaison Committee (ESLC) and approved by it for use by supply authorities and other users.

This section of NRS 097-2 was prepared by a working group which, at the time of publication, comprised the following members:

Dr G Botha (Chairperson)	Corporate Services Division, Eskom
K Albertse	Ekurhuleni Metropolitan Municipality
D Banks	Restio Energy
M Bello	Corporate Services Division, Eskom
C Carter-Brown	Corporate Services Division, Eskom
L Drotsche	Eskom Distribution
Dr H Geldenhuys	Corporate Services Division, Eskom
H Groenewald	Corporate Services Division, Eskom
W Moeng	Eskom
C Purcell	Energy & Development Group
V Rampersad	City Power Johannesburg (Pty) Ltd
A Scholle	Emcon Consulting Group
V Sewchand	Standardization Section, IARC
S Sewchurran	eThekweni Electricity
R van der Riet	City of Cape Town
S van Zyl	Corporate Services Division, Eskom

A Manufacturers' Interest Group (MIG) was consulted on the contents of this section of NRS 097-2 and its comments were incorporated where the working group was in agreement. The MIG comprised the following members:

B Becker	MLT Drives
U Klingenberg	KG Electric
M Malengret	MLT Drives
F Spencer	Alt-e Technologies

NRS 097 consists of the following parts and sections, under the general title *Grid interconnection of embedded generation*:

Part 1: Distribution standard for the interconnection of embedded generation.

The specification sets out the minimum technical and statutory requirements for the connection of embedded generators to medium-voltage and high-voltage utility distribution networks. The specification applies to embedded generators larger than 100 kW. (In course of preparation.)

Part 2: Small-scale embedded generation.

The specification sets out the technical requirements for the utility interface, the embedded generator and the utility distribution network with respect to embedded generation. The specification applies to embedded generators smaller than 100 kW connected to low-voltage networks.

Section 1: Utility interface

Section 2: Embedded generator requirements. (To be developed in the future.)

Section 3: Utility framework. (To be developed in the future.)

Section 4: Procedures for implementation and application. (To be developed in the future.)

NRS 097-2-1:2010

In the definition of “**utility**”, reference is made to the “electricity distribution supply authority”. In South Africa this may be Eskom, or the municipal electricity service provider, or the future RED (Regional Electricity Distributor).

In **4.5**, reference is made to “national regulations” and to “relevant legislation”. In South Africa, this is the Electricity Regulation Act, 2006 (Act No. 4 of 2006) (as amended from time to time) and the Regulations promulgated in terms of the Act

In **4.5** and the footnote, reference is made to “appropriate authority” and “the authority”. In South Africa this is the National Energy Regulator of South Africa (NERSA).

In the footnote to **4.5**, reference is made to “the relevant government department”. In South Africa this is the Department of Energy.

Annexes A and B form an integral part of this document.

Introduction

Renewable electricity generation equipment such as photovoltaic (PV) modules, small wind turbines and micro-hydro turbines has typically been considered (in the South African context) as an off-grid technology, used in areas where it is considered too expensive to bring the grid to a particular customer. However, there are several contexts in which it can be desirable to install small-scale renewable energy generation equipment embedded within the low-voltage distribution network.

Drivers may include

- a) personal, local, regional or national objectives to increase the renewable energy component of electricity utilized (again with a whole range of drivers including sustainability, climate change, future fossil price volatility risk aversion, utility energy shortages, etc.);
- b) changing dynamics of electricity generation costs, with embedded generation close to the source of consumption becoming economically or financially viable; and
- c) in particular contexts where embedded generation may help alleviate localized network capacity constraints or improve power reliability to key circuits on the customer premises (particularly if it can be dispatched or coupled with energy storage).

If utilities can allow embedded renewable energy generation to feed into their networks, this provides a relatively easy way for private sector companies, institutions, and individuals to invest their own resources in renewable generation, without having to undertake detailed own load and storage requirement analysis. The grid acts as a storage facility. This allows considerable leverage of financial resources into the overall renewable energy generation capacity development process.

Where national or local governments define renewable energy objectives, and decide to financially incentivize these through attractive feed-in-tariffs or renewable energy certificates or similar trading systems, small-scale grid-connected options have become a very important component of the overall renewable electricity market.

In South Africa, utilities are receiving an increasing number of requests from customers to allow small-scale embedded generation. As given in the South African Distribution Network Code, the utility is obliged to provide an offer to connect the embedded generator under the conditions in "Application for Connection", referred to in 3.2 of the Distribution Network Code.

Internationally, the grid-connected market for renewable electricity generation technologies (and in particular PV) has become far more important than the off-grid market. For example, by 2007, the global installed base of grid connected PV was estimated to be 7,8 GW, more than twice the off-grid installed capacity (Ren21 (2008)).

A key constraint to the implementation of grid-connected small-scale renewable energy activities in South Africa is the lack of pre-approved, generic standards for utility engineers and system promoters to apply in designing and approving the utility interface. This section of NRS 097-2 and its accompanying parts address this need.

The work on "*Grid interconnection of embedded generation: Small-scale embedded generation*" is based on the following (three key documents):

- utility interface (*this document*);
- embedded generator requirements, which deal with product type approval, installation requirements and certificate of compliance on the EG customer's side of the meter (a future document); and

NRS 097-2-1:2010

- utility framework, which deals specifically with the commonly designed unidirectional flow of energy in LV networks, with cumulative impacts of EGs, with substation configuration and metering arrangements (a future document).

In addition, a specification will in the future be developed to provide informative guidelines on the implementation procedures, the application form, the license requirements, the certificate of compliance procedures, the commissioning procedures, where applicable, and documentation requirements for the embedded generator. The document will address legal issues such as agreements and ownership, and also metering and revenues from feed-in tariffs. In the case of the utility, it will provide guidelines for the registration process and the record keeping of embedded generators within utility networks and network spurs.

This section of NRS 097-2 aims to be technology neutral and focuses on the interface between the embedded generator and the utility, although it is expected that the specification will mainly apply to photovoltaic grid connected systems interfaced through static power converter technology. Static power converters are also utilized to convert for example, wind power, micro-hydro power, pico hydro power, battery storage energy and fuel cells to grid compatible electricity. Other conversion technologies are considered where the requirements deviate from those of static power converters. These include induction generators (where the primary resource may for example be wind or hydro) and synchronous generators (where the primary resource may for example be wind, micro-hydro or diesel).

Keywords

backup supply, embedded generation, metering, utility interface.

Contents

	Page
1 Scope	3
2 Normative references	3
3 Terms, definitions and abbreviations	4
4 Requirements	7
4.1 Utility compatibility	7
4.2 Safety and protection.....	9
4.3 Metering	13
4.4 UPS with embedded generation	16
4.5 Generation license.....	19
Annex A (normative) Notes to purchasers	20
Annex B (normative) Earthing systems	21
Bibliography	29

This page intentionally left blank

GRID INTERCONNECTION OF EMBEDDED GENERATION

Part 2: Small-scale embedded generation

Section 1: Utility interface

1 Scope

This section of NRS 097-2 defines standards for the utility interface for the interconnection of small-scale embedded generation to a utility network.

This section of NRS 097-2 applies to embedded generators of nominal capacity less than 100 kW, connected to a single-phase, dual phase, or three-phase low-voltage utility network.

This section of NRS 097-2 aims to provide a practical specification for utilities to facilitate the incorporation of embedded generation on low-voltage networks while ensuring compliance of the utility interface with the requirements documented in this specification.

NOTE The 100 kW value, specified as the “boundary” between EGs connected to LV networks and EGs connected to HV/MV networks, will be revisited and reviewed as the industry evolves.

2 Normative references

The following documents contain provisions which, through reference in this text, constitute provisions of this section NRS 097-2. All documents are subject to revision and, since any reference to a document is deemed to be a reference to the latest edition of that document, parties to agreements based on this specification are encouraged to take steps to ensure the use of the most recent editions of the documents listed below. Information on currently valid national and international standards can be obtained from the SABS Standards Division.

EA Engineering Recommendation G83/1-1: Amendment 1-June 2008, *Recommendation for the connection of small-scale embedded generators (up to 16 A per phase) in parallel with the public low-voltage distribution networks*. Available for purchase from the World Wide Web at <www.ena-eng.org/ENA-Docs>.

IEC 60364-7-712, *Electrical installations of buildings – Part 7-712: Requirements for special installations or locations – Solar photovoltaic (PV) power supply systems*.

IEC 61727, *Photovoltaic (PV) systems – Characteristics of the utility interface*.

IEC 62116:2008 (ed. 1), *Test procedure of islanding prevention measures for utility-interconnected photovoltaic inverters*.

NRS 048-2, *Electricity supply – Quality of supply – Part 2: Voltage characteristics, compatibility levels, limits and assessment methods.*

SANS 10142-1, *The wiring of premises – Part 1: Low-voltage installations.*

SANS 60947-2/IEC 60947-2, *Low-voltage switchgear and controlgear – Part 2: Circuit-breakers.*

3 Terms, definitions and abbreviations

For the purposes of this document, the following terms, definitions and abbreviations apply.

3.1 Terms and definitions

asynchronous generator

induction generator

type of rotating electrical generator that operates at a speed not directly related to system frequency, the machine of which is designed to be operated in parallel with a network that contains other generation as the output voltage, and frequency is determined by the system to which it is connected

NOTE A mains-excited asynchronous generator will cease generation on disconnection of the parallel connection. Power-factor corrected and self-excited asynchronous generators are derivatives of the mains-excited generator.

backup supply

power system that operates as a backup supply during loss-of-grid conditions, consists of storage (in the form of batteries, fossil fuels or fuel cells) and a synchronous static power converter or a generator which is able to operate in stand-alone mode

NOTE Examples of a generator that operates in stand-alone mode are a UPS or a diesel generator.

bi-directional meter

meter that measures the active energy (Wh) flow in both directions (import and export) and either displays the balance of the imported and exported energy in a single register meter (net metering) or displays both imported and exported energy in separate registers

NOTE Active energy flow in a meter is measured in watt-hours (Wh).

customer network

electrical installation downstream of the electricity consumption meter, usually on the customer premises

NOTE This network can be backed up and operate as an island provided that it complies with the safety and protection requirements of this specification.

disconnection switching unit

switching unit that disconnects the embedded generator operating in parallel with the utility network from the network in response to an out-of-bounds condition

embedded generator

EG

one or more energy generation sources that includes the energy conversion device (devices), the static power converter (converters), if applicable, and the control and protection gear within a customer's network that operate in synchronism with the utility's supply

NOTE 1 Examples of energy conversion devices are photovoltaic modules, fuel cells, induction generators or synchronous generators.

NOTE 2 Embedded generation is also referred to as “distributed” or “dispersed generation” in other documents.

feed-in tariff**FIT**

mechanism to promote the deployment of renewable energy that places an obligation on specific entities to purchase the output from qualifying renewable energy generators at pre-determined premium prices

NOTE The tariffs are structured according to the renewable energy technology employed and allow the owner to incur reasonable profits from investing into renewable energy generation.

island

state in which a portion of the utility’s or customer’s network, containing load and generation, continues to operate isolated from the rest of the grid; the generation and loads may be any combination of customer-owned and utility-owned

loss-of-grid

condition in which supply from the utility network is interrupted for whatever reason

low voltage**LV**

nominal voltage levels up to and including 1 kV

NOTE For the purposes of this specification, low voltage is defined as 230 V a.c. for single phase, 460 V a.c. line-to-line for dual phase and 400 V a.c. line-to-line for three-phase.

parallel operation

operation of the embedded generator which is synchronized to the grid and operates in parallel to the network

photovoltaic**PV**

method of generation of d.c. electricity by a device when exposed to solar radiation

point of utility connection

interconnection between the embedded generator and the utility distribution network, referring to the node on the utility network electrically closest to a particular embedded generator’s installation

power factor

ratio of the r.m.s. value of the active power to the apparent power, measured over the same integrating period

NOTE Active power is measured in kilowatts and apparent power in kilovolt-amperes.

prevention of islanding

embedded generator’s ability to detect loss-of-grid and prevent the condition of unintended islanding

safety disconnect

independent control system that monitors the utility network conditions and disconnects the a.c. output of the embedded generator from the network for out-of-bounds conditions

simple separation

galvanic separation between circuits or between a circuit and earth by means of basic insulation

small-scale embedded generator

one or more energy generation sources rated at up to 100 kW which includes the energy conversion device (devices), the static power converter (converters), if applicable, and the control and protection gear within a customer's network that operates in synchronism with the utility's low-voltage supply

NOTE Examples of energy conversion devices are photovoltaic modules, fuel cells, induction generators and synchronous generators.

static power converter

power electronic device that converts variable d.c. or a.c. to grid compatible a.c. either synchronously (able to operate in stand-alone mode) or asynchronously (requires utility interconnection)

synchronous generator

type of rotating electrical generator that operates at a speed which is directly related to system frequency and is capable of operating in isolation from other generating plants

total harmonic distortion**THD**

ratio of the r.m.s. value of the harmonics to the r.m.s. value of the fundamental and is defined as:

$$THD_x = \frac{\sqrt{\sum_{n=2}^{\infty} x_n^2}}{x_1}$$

where

x_n is the r.m.s. harmonic voltage or current of the order n ;

x_1 is the r.m.s. fundamental voltage or current.

uni-directional meter

meter that measures the active energy flow in one direction only and ignores the active energy flow in the reverse direction

NOTE Active energy is measured in watt-hours (Wh).

uninterruptible power supply system**UPS**

power system that comprises a synchronous static power converter, a charger, switchgear, control circuitry and a means of energy storage (e.g. batteries) for maintaining continuity of electricity supply to a load in the case of a disruption of power supply from an electricity distribution network

utility

electricity distribution supply authority (see foreword), in the area of the installation responsible for the low-voltage electricity network infrastructure

utility-interconnected inverter

asynchronous static power converter

utility network

electricity distribution infrastructure operated and controlled by the utility

3.2 Abbreviations

a.c.:	alternating current
CB:	circuit-breaker
COC:	certificate of compliance
DB:	distribution board
d.c.:	direct current
EA:	electricity association
E/L:	earth leakage
EG:	embedded generator
FIT:	feed-in tariff
PUC:	point of utility connection
PV:	photovoltaic
r.m.s.:	root mean square
THD:	total harmonic distortion
UPS:	uninterruptible power supply

4 Requirements

4.1 Utility compatibility

4.1.1 General

4.1.1.1 This clause describes the technical issues and the responsibilities related to interconnecting an embedded generator to a utility network. Subclauses 4.1 and 4.2 are based on IEC 61727:2004.

4.1.1.2 The quality of power provided by the embedded generator in the case of the on-site a.c. loads and the power delivered to the utility is governed by practices and standards on voltage, flicker, frequency, harmonics and power factor. Deviation from these standards represents out-of-bounds conditions. The embedded generator is required to sense the deviation and might need to disconnect from the utility network.

4.1.1.3 All power quality parameters (voltage, flicker, frequency and harmonics) shall be measured at the PUC, unless otherwise specified (see annex A). The power quality shall comply with NRS 048-2. This implies that the combined voltage disturbances caused by the specific EG and other customers, added to normal background voltage disturbances, may not exceed levels stipulated by NRS 048-2.

NOTE The frequency cannot be changed by an EG.

4.1.1.4 The embedded generator's a.c. voltage, current and frequency shall be compatible with the utility system in accordance with IEC 61727.

4.1.1.5 The embedded generator shall be type approved, unless otherwise agreed upon with the utility (see annex A).

4.1.1.6 The maximum size of the embedded generator is limited to the rating of the supply point on the premises.

4.1.1.7 Embedded generators larger than 10 kW shall be of the three-phase type.

NOTE This value refers to the maximum export potential of the generation device.

4.1.1.8 A customer with a multiphase connection shall split the embedded generator over all phases if the EG is larger than 6 kW.

NOTE 1 Balancing phases in a multiphase embedded generator is deemed desirable.

NOTE 2 In the case of long feeder spurs the maximum desired capacity of the EG might require approval by the utility and might result in the requirement for a three-phase connection.

4.1.2 Normal voltage operating range

4.1.2.1 In accordance with IEC 61727, utility-interconnected embedded generators do not normally regulate voltage, they inject current into the utility. Therefore the voltage operating range for embedded generators is designed as protection which responds to abnormal utility network conditions and not as a voltage regulation function.

4.1.2.2 The embedded generator shall synchronise (see 4.1.8) with the utility network before a connection is established. The embedded generator shall not control the voltage, unless agreed to by the utility (see annex A).

4.1.3 Flicker

The operation of the embedded generator, in conjunction with other existing and future loads at the same point of connection, shall not cause flicker levels to increase beyond the levels specified in NRS 048-2.

4.1.4 DC injection

The static power converter of the embedded generator shall not inject d.c. current exceeding 1 % of the rated a.c. output current into the utility a.c. interface under any operating condition in accordance with IEC 61727. This relates specifically to embedded generators where the static power converter has no simple separation from the utility network (e.g. inverters that are transformer-less).

4.1.5 Normal frequency operating range

An embedded generator that operates in parallel with the utility system shall operate within the frequency trip limits defined in 4.2.2.3.3.

4.1.6 Harmonics and waveform distortion (in accordance with IEC 61727)

4.1.6.1 Only devices that inject low levels of current and voltage harmonics will be accepted; the higher harmonic levels increase the potential for adverse effects on connected equipment.

4.1.6.2 Acceptable levels of harmonic voltage and current depend upon distribution system characteristics, type of service, connected loads or apparatus, and established utility practice.

4.1.6.3 The embedded generator output shall have low current-distortion levels to ensure that no adverse effects are caused to other equipment connected to the utility system.

4.1.6.4 Total harmonic current distortion shall be less than 5 % at rated generator output in accordance with IEC 61727. Each individual harmonic shall be limited to the percentages listed in table 1.

Table 1 — Current distortion limit as a function of harmonics (Source: IEC 61727:2004)

1	2
Odd harmonics	Distortion limit
3 rd through 9 th	Less than 4,0 %
11 th through 15 th	Less than 2,0 %
17 th through 21 st	Less than 1,5 %
23 rd through 33 rd	Less than 0,6 %

Even harmonics	Distortion limit
2 nd through 8 th	Less than 1,0 %
10 th through 32 nd	Less than 0,5 %

4.1.7 Power factor

The embedded generator shall not inject reactive power into the utility network, while the drain of reactive power shall be limited to a power factor of 0,9. These limits apply, unless otherwise agreed upon with the utility (see annex A).

4.1.8 Synchronization

4.1.8.1 The embedded generator shall synchronize with the utility network before the parallel connection is made.

4.1.8.2 Automatic synchronization equipment shall be the only method of synchronization.

4.1.8.3 The limits for the synchronizing parameters for each phase are

- a) frequency difference: 0,3 Hz,
- b) voltage difference: 5 % = 11,5 V per phase, and
- c) phase angle difference: 20°.

4.2 Safety and protection

4.2.1 General

The safe operation of the embedded generator in conjunction with the utility network shall be ensured at all times.

4.2.2 Safety disconnect from utility network

4.2.2.1 General

The embedded generator shall automatically and safely disconnect from the grid in the event of an abnormal condition. Abnormal conditions include

- a) network voltage or frequency out-of-bounds conditions,
- b) loss-of-grid conditions, and d.c. current injection threshold exceeded.

4.2.2.2 Disconnection switching unit

4.2.2.2.1 The embedded generator shall be equipped with a disconnection switching unit which separates the embedded generator from the grid due to the above abnormal conditions. The disconnection unit may be integrated into one of the components of the embedded generator (for example the PV utility-interconnected inverter) or may be an independent device installed between the embedded generator and the utility interface.

4.2.2.2.2 The disconnection switching unit shall be able to operate under all operating conditions of the utility network.

4.2.2.2.3 A failure within the disconnection switching unit shall lead to disconnection and indication of the failure condition.

4.2.2.2.4 A single failure within the disconnection switching unit shall not lead to failure to disconnect. Failures with one common cause shall be taken into account and addressed through adequate redundancy.

4.2.2.2.5 The disconnection switching unit shall disconnect from the network by means of two series switches. Each switch shall be separately rated to the embedded generator's nominal power output. At least one of the switches shall be an electromechanical switch while the second switch may be part of the existing solid state switching circuits of a utility-interconnected static power converter. The electromechanical switch shall disconnect the embedded generator on the neutral and the live wire(s).

NOTE 1 The switching unit need not disconnect its sensing circuits.

NOTE 2 A mains-excited induction generator requires only a single disconnection switch as the generator requires excitation from the utility network to operate.

NOTE 3 A static power converter without simple separation should make use of two series-connected electromechanical disconnection switches.

4.2.2.2.6 The fault current breaking capacity of the disconnecting switch shall be appropriately sized for the application.

4.2.2.3 Overvoltage, undervoltage and frequency

4.2.2.3.1 General

Abnormal conditions can arise on the utility system and requires a response from the connected embedded generator. This response is to ensure the safety of utility maintenance personnel and the general public, and also to avoid damage to connected equipment. The abnormal utility conditions of concern are voltage and frequency excursions above or below the values stated in this clause. The embedded generator shall disconnect if these conditions occur.

4.2.2.3.2 Overvoltage and undervoltage

The embedded generator shall cease to energize the utility distribution system should the network voltage deviate outside the conditions specified in table 2. This applies to any phase of a multiphase system. The system shall sense abnormal voltage and respond. The following conditions shall be met, with voltages in r.m.s. and measured at the PUC.

NOTE All discussions regarding system voltage refer to the nominal voltage.

Table 2 – Response to abnormal voltages

1	2
Voltage range (at point of utility connection)	Maximum trip time s
$V < 50 \%$	0,2 s
$50 \% \leq V < 85 \%$	2 s
$85 \% \leq V \leq 110 \%$	Continuous operation
$110 \% < V < 120 \%$	2 s
$120 \% \leq V$	0,16 s

The purpose of the allowed time delay is to ride through short-term disturbances to avoid excessive nuisance tripping. The generator does not have to cease to energize if the voltage returns to the normal utility continuous operating condition within the specified trip time.

A customer with a multiphase connection and a single-phase embedded generator above 3 kW shall monitor all phases for out-of-bounds voltage conditions. The EG shall be disconnected if an out-of-bounds voltage condition is detected on any of the phases.

4.2.2.3.3 Overfrequency and underfrequency

The embedded generation system shall cease to energize the utility network when the utility frequency deviates outside the specified conditions.

When the utility frequency is outside the range of 47,5 Hz and 52 Hz, the system shall cease to energize the utility line within 0,5 s in accordance with EA Engineering Recommendation G83/1-1: Amendment 1-June 2008. The purpose of the allowed range and time delay is to allow continued operation for short-term disturbances and to avoid excessive nuisance tripping in weak utility system conditions. The plant does not have to cease to energize if the frequency returns to the normal utility continuous operating condition within the specified trip time.

4.2.2.4 Prevention of islanding

4.2.2.4.1 A utility distribution network can become de-energized for several reasons: for example, a substation breaker that opens due to a fault condition or the distribution network might be switched off for maintenance purposes. Should the load and (embedded) generation within an isolated network be closely matched, then the voltage and frequency limits may not be triggered. If the embedded generator control system only made use of passive voltage and frequency out-of-bounds detection, this would result in an unintentional island that could continue beyond the allowed time limits.

4.2.2.4.2 In order to detect an islanding condition, the embedded generator shall make use of at least one active islanding detection method. An active islanding detection method intentionally varies an output parameter and monitors the response or it attempts to cause an abnormal condition at the utility interface to trigger an out-of-bounds condition. If the utility supply is available, the attempt to vary an output parameter or cause an abnormal condition will fail and no response will be detected. However, if the utility supply network is de-energized, there will be a response to the change which can be detected. This signals an island condition to the embedded generator upon detection of which the embedded generator shall cease to energize the utility network within a specific time period.

4.2.2.4.3 Active islanding shall be detected in all cases where the EG interfaces with the utility network through one or more static power converters.

4.2.2.4.4 Synchronous generators, power-factor corrected induction generators and self-excited induction generators shall use an islanding detection method acceptable to the utility (e.g. rate-of-

change-of-frequency or voltage vector shift detection). Mains-excited induction generators are not required to be fitted with such islanding detection capabilities.

4.2.2.4.5 This section of NRS 097-2 requires that an islanding condition shall cause the embedded generator to cease to energize the utility network within 2 s, irrespective of connected loads or other embedded generators. The embedded generator shall comply with the requirements of IEC 62116 (ed. 1).

NOTE Prevention of islanding measures are only considered on the embedded generator side, i.e. no utility installed anti-islanding measures are considered.

4.2.2.4.6 The embedded generator shall physically disconnect from the utility network in accordance with the requirements in 4.2.2.2.

4.2.2.5 DC current injection

The static power converter of the embedded generator shall not inject d.c. current greater than 1 % (see IEC 61727:2004) of the rated a.c. output current into the utility interface under any operating condition. The EG shall cease to energize the utility network within 500 ms if this threshold is exceeded.

4.2.3 Response to utility recovery

After a voltage or frequency out-of-range condition that has caused the embedded generator to cease energizing the utility network, the generator shall not re-energize the utility network for 60 s after the utility service voltage and frequency have recovered to within the specified ranges.

4.2.4 Isolation

4.2.4.1 The embedded generator shall provide a means of isolating from the utility interface in order to allow for safe maintenance of the EG. The disconnection device shall be a double pole for a single-phase EG, a three-pole for a three-phase delta-connected EG, and a four-pole for a three-phase star-connected EG. The grid supply side shall be wired as the source.

4.2.4.2 The breaking capacity of the isolation circuit-breaker closest to the point of utility connection shall have a minimum fault current level of 6 kA in accordance with SANS 60947-2.

4.2.4.3 This disconnection device does not need to be accessible to the utility.

4.2.5 Earthing

4.2.5.1 The electrical installation shall be earthed in accordance with SANS 10142-1. The earthing requirements for different embedded generation configurations in conjunction with the customer network are described in annex B for the most common earthing systems.

4.2.5.2 The embedded generator shall be protected by an earth leakage unit. The embedded generator shall not be connected to any of the customer network earth leakage protection units.

4.2.5.3 Utility-interconnected inverters without simple separation shall make use of earth leakage circuit-breakers which are able to respond to d.c. fault currents including smooth d.c. fault currents (i.e. without zero crossings) unless the inverter can exclude the occurrence of d.c. leakage currents through its circuit design¹⁾.

NOTE The earth leakage unit may also fulfil the requirement of the all-pole disconnection device as stated in 4.2.4.

1) The appropriate earth leakage unit should be selected to accommodate the higher leakage current of inverters without transformers to avoid nuisance tripping.

4.2.6 Short-circuit protection

The embedded generator shall have short-circuit protection in accordance with IEC 60364-7-712. The short-circuit characteristics for rotating generators shall be supplied to the utility.

4.2.7 Labelling

4.2.7.1 A label on the distribution board of the premises where the embedded generator is connected, shall state: "ON-SITE EMBEDDED GENERATION (EG) CONNECTED. THE EG IS FITTED WITH AN AUTOMATIC DISCONNECTION SWITCH WHICH DISCONNECTS THE EG IN THE CASE OF UTILITY NETWORK DE-ENERGIZATION."

4.2.7.2 The label shall be permanent, coloured red, and with white lettering of height at least 8 mm.

4.3 Metering

4.3.1 General

4.3.1.1 All meters utilized by the utility shall be the property of the utility even when the meters are located on the premises of the customer. Meters that are embedded in the customer's network shall be accessible to the utility on request.

4.3.1.2 Three metering configurations are acceptable in the case of premises where embedded generators are operated. One configuration applies to net metering where price symmetry is given between consumption and generation and two configurations apply to feed-in tariff (FIT) metering. The details are given in 4.3.2 and 4.3.3.

4.3.2 Net metering

4.3.2.1 Net metering applies when the consumption tariff is equal to the embedded generation tariff.

4.3.2.2 The net metering arrangement is given in figure 1 and is based on a single bi-directional meter.

4.3.2.3 The EG feeds into the customer network (L), offsetting the customer's own consumption. If the customer is a net electricity importer from the utility (U), the cumulative consumption meter reading will increase. If the customer is a net exporter, the cumulative consumption meter reading decreases.

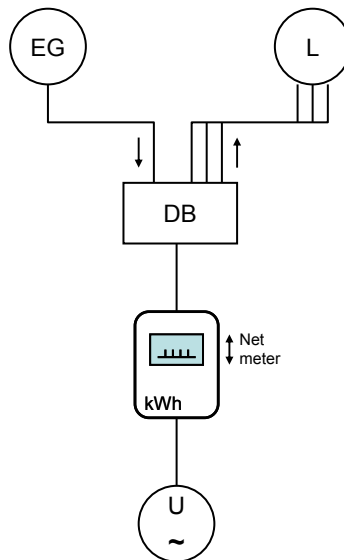

Legend

DB distribution board
 EG embedded generation
 L customer network
 U utility network

Figure 1 — Net metering

4.3.2.4 As a result of using a single meter, the overall consumption and generation of the customer is not recorded. Only the net import and export of energy is metered and balanced.

NOTE A net meter records and balances energy in a single register. An alternative to the net meter is a bi-directional meter which records energy import and export in separate registers. The registers need to be balanced off against each other to provide the necessary information to the billing system. Separate register meters may be preferred by utilities for reasons of revenue protection.

4.3.3 Feed-in tariff metering

4.3.3.1 Feed-in tariff metering records all the energy generated from the embedded generator and reimburses the EG customer at the set FIT. The consumption of the EG customer is recorded in full and billed in the conventional manner. A customer with embedded generation and consumption therefore requires two meters.

4.3.3.2 The metering configuration for FIT metering is given in figure 2 and is referred to as “separate metering”. An existing consumption meter, whether prepayment or conventional, can remain in place. The embedded generation meter shall be a bi-directional active energy meter that records energy flow in both directions.

4.3.3.3 This metering configuration records overall consumption (L) and overall generation (EG) which is exported to the utility network (U).

4.3.3.4 The separate metering configuration in figure 2 is the most basic FIT metering configuration.

NOTE The relevant regulations applicable in municipalities may not allow this metering configuration in which case the EG can be connected through the separate embedded generation metering configuration shown in figure 3.

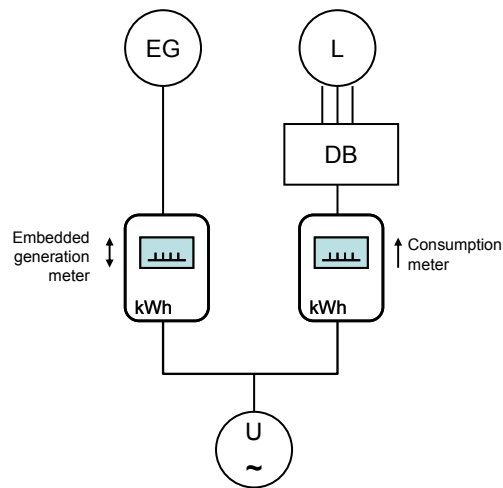

Legend

- DB distribution board
- EG overall generation
- L overall consumption
- U utility network

Figure 2 — Separate metering

4.3.3.5 In the case where the output of the EG cannot physically be taken to the main distribution board of the customers premises, an EG meter may be embedded in the customer’s network. The appropriate metering configuration is given in figure 3.

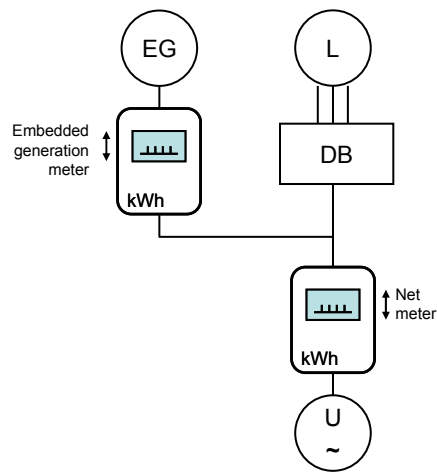

Legend

- DB distribution board
- EG embedded generation
- L consumption
- U utility network

Figure 3 — Separate embedded metering

4.3.3.6 The overall generation of the EG is recorded in the bi-directional embedded generation meter while the overall consumption is balanced off between the net meter and the EG meter²⁾. The net meter shall be a bi-directional meter.

4.3.4 Types of meter

4.3.4.1 Energy meters used in conjunction with embedded generation shall record active energy. The meters shall be conventional electronic, bi-directional type meters. The meters can either be of the single or the separate register type.

4.3.4.2 Pre-payment meters require separate registers in order to record import and export of power separately³⁾.

4.3.4.3 In the event that embedded generators are required to record reactive energy in conjunction with active energy, four-quadrant conventional electronic meters shall be utilized. This applies to all the meters shown in figures 1 to 3, except for the consumption meter in figure 2 which shall be either a uni-directional or a two-quadrant meter, depending on the type of connection.

4.3.4.4 In the event that embedded generation projects of less than 100 kW can levy demand charges, four-quadrant electronic demand meters shall be utilized. This applies to all meters shown in figures 1 to 3, except for the consumption meter in figure 2 which shall either be a uni-directional, a two-quadrant or a two-quadrant demand meter, depending on the type of connection.

4.3.4.5 Meters with the capability of metering quality of supply parameters shall activate the monitoring facility on the meter.

NOTE The modalities of the billing and revenue procedures for EG customers will be addressed in the future NRS 097-2-4.

4.4 UPS with embedded generation

4.4.1 General

4.4.1.1 A UPS powers all or part of the customer's network during loss-of-grid conditions and recharges its storage during utility network energization.

4.4.1.2 A UPS that cannot operate in parallel with the utility network (i.e. is unable to export energy to the utility side) shall comply with 7.12.2.5 of SANS 10142-1:2009 with regard to a change-over switch between the main supply and the backup supply.

4.4.1.3 A UPS that can operate in parallel with the utility network (i.e. is able to export energy to the utility side) shall comply with the safety disconnection requirements in 4.2.2.2.

4.4.1.4 A label shall be fitted on the distribution board to which the UPS is connected stating: "BACKUP POWER SUPPLY CONNECTED." The label shall be permanent, coloured red, and with white lettering of height at least 8 mm.

4.4.1.5 The customer's network, which is powered through the UPS, shall have earth leakage protection in accordance with the requirements in 6.7.5 in SANS 10142-1:2009.

2) The overall electricity consumption over a period is equivalent to the sum of the net meter differential reading and the EG meter differential reading.

3) Single register prepayment meters deduct credit when load is drawn by the customer. However, when a customer exports energy to the utility network, credit is still decremented from the register or, alternatively, the meter goes into tamper alert. This is a revenue protection feature that renders single register prepayment meters unsuitable for embedded generation.

4.4.2 UPS with a.c. coupled EG

4.4.2.1 A system that consists of a UPS with an a.c. utility-interconnected EG, where the EG can energize the UPS during loss-of-grid, shall comply with the requirements in 4.4.1.3 if the UPS is capable of exporting to the utility network. If the UPS is not able to export to the utility network, the system shall comply with the requirements in 4.4.1.2.

4.4.2.2 The metering configurations applicable in the case of a UPS with a.c. coupled EG are

- net metering as in figure 1 where the EG now represents both the UPS and the EG, and
- FIT metering as given in figure 4.

NOTE Figure 4 illustrates only the embedded generator change-over switch. The additional switches required to comply with the requirements for safety disconnection of the EG and the UPS are given in 4.2.2.

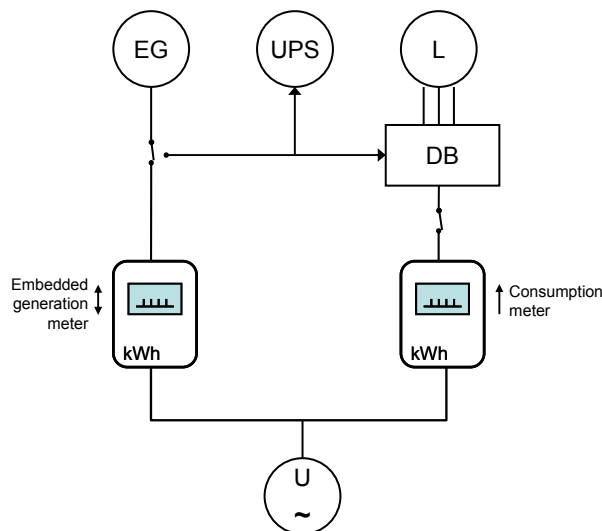

Legend

- DB distribution board
- EG embedded generation
- L consumption
- U utility network
- UPS uninterruptible power system

Figure 4 — Separate metering: UPS with a.c. coupled embedded generation

4.4.2.3 The UPS is tied to the load side and will power the customer loads (or a selection thereof) during loss-of-grid conditions. The EG changes over to the UPS during a power failure to assist the UPS load circuit or storage. The UPS is recharged through the consumption meter on utility network recovery and the EG switches back to generate through the EG meter.

4.4.2.4 An existing consumption meter can remain in place.

4.4.2.5 The metering configuration in figure 4 can also follow the metering arrangement as given in figure 3 if the arrangement in figure 4 is not acceptable to the utility in which the EG is connected.

4.4.3 UPS with d.c. coupled EG

4.4.3.1 A system that consists of a UPS with a d.c. coupled EG can only export energy through the UPS if that function is available. If the UPS can export energy to the utility network, it shall comply with the requirements in 4.4.1.3. If the UPS cannot export energy, it shall comply with the requirements in 4.4.1.2.

4.4.3.2 The metering configurations applicable in the case of a UPS with d.c. coupled EG and exporting capabilities are

- a) net metering as in figure 1 where the EG now represents both the UPS and the EG, and
- b) FIT metering as given in figure 5.

NOTE Figure 5 illustrates only the UPS change-over switch. The additional switches required to comply with the requirement for safety disconnection of the UPS are given in 4.2.2.

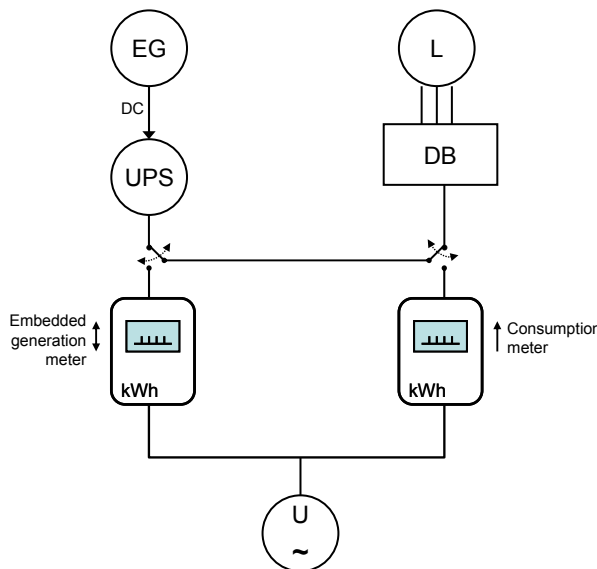

- DB distribution board
- EG embedded generation
- L consumption
- U utility network
- UPS uninterruptible power system

Figure 5 — Separate embedded metering: UPS with d.c. coupled embedded generation

4.4.3.3 The UPS is linked to the embedded generator and exports energy through the EG meter at FIT rates. The UPS powers the customer loads (or a selection thereof). On utility network re-energization, the UPS storage is recharged by the EG and through the embedded generation meter. The logic of this metering configuration is similar to figure 3.

4.4.3.4 The embedded generation meter and the consumption meter shall be bi-directional meters.

4.5 Generation license⁴⁾

In terms of the applicable national regulations (see foreword), all electricity generators, regardless of size, require a generation license. The owner of the embedded generator therefore needs to file a license application (*Application for a license to generate electricity*) in accordance with relevant legislation (see foreword) with the appropriate authority (see foreword).

4) The appropriate authority (see foreword) has submitted a request to the relevant government department (see foreword) which recommends that all generators above 1 MW require a license from the authority (see foreword) while generators of less than 1 MW are required to register with the authority. The license requirements may change depending on the outcome of the government department's review.

Annex A
(normative)

Notes to purchasers

A.1 The following requirements shall be specified in tender invitations and in each order or contract:

- whether all power quality parameters shall be measured at the PUC (see 4.1.1.3).

A.2 The following requirements shall be agreed upon between the customer and the utility:

- a) whether the EG shall be type approved (see 4.1.1.5);
- b) whether the EG may control the voltage (see 4.1.2.2);
- c) the power factor limits (see 4.1.7).

Annex B (normative)

Earthing systems

B.1 Application of SANS 10142-1

B.1.1 General

SANS 10142-1 applies to low-voltage wiring, earthing, bonding and safety. The requirements in B.1.2 to B.1.5 relating to earthing and to neutral and earth path connections apply.

B.1.2 Neutral conductor

The neutral conductor shall not be connected direct to earth or to the earth continuity conductor on the load side of the point of control (see 6.1.6 in SANS 10142-1:2009).

B.1.3 Customer's earth terminal

Each installation shall have a consumer's earth terminal (see 3.18 of SANS 10142-1:2009) at or near the point where the supply cables enter the building or structure. All conductive parts that are to be earthed (see 6.12.3 in SANS 10142-1:2009) shall be connected to the main earthing terminal (see 3.29.4 in SANS 10142-1:2009), which shall be connected to the consumer's earth terminal. The consumer's earth terminal shall be earthed by connecting it to the supply earth terminal (see 3.78 in SANS 10142-1:2009) or the protective conductor (see 3.15.8 in SANS 10142-1:2009) and, if installed, the earth electrode. The effectiveness of the supply protective conductor shall be determined in accordance with 8.7.5 in SANS 10142-1:2009 (see 6.11.1 as amended by amendment No. 6 in SANS 10142-1:2009).

B.1.4 Earthing of combined sources

When an installation that has a common neutral is supplied from a combination of transformers and generators located near one another, the neutral terminal of these shall be connected to a single neutral bar. This neutral bar shall be the only point at which the neutral of the installation is earthed except in the case in 7.12.3.1.3 in SANS 10142-1:2009 (see 6.12.4 as amended by amendment No. 6 in SANS 10142-1:2009).

B.1.5 Neutral bar earthing

B.1.5.1 Protection in accordance with the requirements in 6.7 in SANS 10142-1:2009 shall be provided for the electrical installation in such a manner as to ensure correct operation of the protection devices, irrespective of the supply or combination of sources of supply. Operation of the protection devices shall not rely upon the connection to the earthing point of the main supply.

B.1.5.2 Where there is no existing earth electrode in the electrical installation, a suitable earth electrode may be installed in accordance with SANS 10199. When installed, the electrode shall be bonded to the consumer's earth terminal and to the earthing point of the generating set with a conductor of at least half the cross-section of that of the phase conductor, but not less than 6 mm copper, or equivalent. This also applies to a single-phase supply.

NOTE 1 In the case of the TN system of electricity supply, an earth electrode is normally not required in an electrical installation (see 7.12.3.1.1 as amended by amendment No. 6 in SANS 10142-1:2009).

NOTE 2 IEC 60364-1 distinguishes three families of earthing arrangement, using the two-letter codes TN, TT, and IT. The first letter indicates the connection between earth and the power-supply equipment (generator or transformer). The second letter indicates the connection between earth and the electrical device being supplied. In the case of TN systems, T indicates a direct connection of a point with earth (Latin: terra) and N indicates direct connection to neutral at the origin of the installation, which is connected to the earth.

B.1.5.3 When an installation is supplied from a combination of transformers and generators located near one another, including alternative supplies, the neutral terminal of these shall be connected to a single earthed neutral bar. This neutral bar shall be the only point at which the neutral of the installation is earthed. Any earth leakage unit shall be positioned to avoid incorrect operation due to the existence of the parallel neutral or earth path (see 7.12.3.1.2 as amended by amendment No. 6 in SANS 10142-1:2009).

B.1.5.4 Where alternative supplies are installed remotely from the installation and it is not possible to make use of a single neutral bar, which is earthed, the neutral of each unit shall be earthed at the unit and these points shall be bonded to the consumer's earth terminal (see 6.12.4 of SANS 10142-1:2009). The supply that supplies the installation or part of the installation shall be switched by means of a switch that breaks all live conductors operating substantially together (see annex S of SANS 10142-1:2009), to disconnect the earthed neutral point from the installation neutral when the alternative supply is not connected (see also 6.1.6 of SANS 10142-1:2009 and 7.12.3.1.3 (as amended by amendment No. 6 in SANS 10142-1:2009)).

B.1.5.5 Where only part of an installation is switched to the alternative supply in the same distribution board, the neutral bar shall be split (see figure S.2 in annex S of SANS 10142-1:2009) and 7.12.3.1.3 (as amended by amendment No. 6 in SANS 10142-1: 2009).

B.2 Embedded generator and UPS configurations

B.2.1 Various configurations of embedded generator and UPS systems were examined, and cross-referenced with the main electrical supply earthing configurations (i.e. TN-S, TN-C-S). Table B.1 shows the permutations explored.

NOTE The TT configuration is generally not used in South Africa, but could sometimes be found in certain rural electrification network spurs.

B.2.2 Tables B.2 to B.5 illustrate the typical system application types and connections.

Table B.1 — Generic embedded generation/UPS type versus electricity supply configuration

1	2	3	4	5	6
Figure reference	Application type	Backup supply characteristic	Main electricity supply system configuration examined		
		Internal N-PE bridge connection	TN-S	TN-C-S	TT
Table B.2	Backup generator, e.g. stand-by diesel or stand-alone generator	Unbridged N-PE	Y	Y	Y
		N-PE bridged	Y	Y	Y
Table B.3	Embedded generator, e.g. utility interconnected PV system		Y	Y	Y
Table B.4	UPS system with a.c. coupled embedded generator	Unbridged N-PE	Y	Y	Y
		N-PE bridged	Y	Y	Y
Table B.5	UPS system	Unbridged N-PE	Y	Y	Y
		N-PE bridged	Y	Y	Y
	UPS system with d.c. coupled embedded generator (e.g. PV or wind)	Unbridged N-PE	Y	Y	Y
		N-PE bridged	Y	Y	Y

Annex B

Table B.2 — Diesel generator in backup supply configuration

1 Supply earthing system	2 Wiring diagram	3 Earthing comments
<p>TN-S</p> <ul style="list-style-type: none"> • Five-wire supply. • Consumer's earth electrode not required. • No N-PE bridge on consumer's earth terminal 		<p>Requirements</p> <ul style="list-style-type: none"> • Backup supply earth electrode required • Bridge N-PE required on backup supply. • Four-pole change-over switch required.
<p>TN-C-S</p> <ul style="list-style-type: none"> • Four-wire supply. • Consumer's earth electrode not required. • Bridge N-PE required on consumer's earth terminal 		<p>Requirements</p> <ul style="list-style-type: none"> • Backup supply earth electrode required <p>Options</p> <ul style="list-style-type: none"> • If bridged N-PE on backup supply, then four-pole change-over switch required. • If open N-PE on backup supply, then three-pole change-over switch required.
<p>TT</p> <ul style="list-style-type: none"> • Four-wire supply. • Consumer's earth electrode required. • No N-PE bridge on consumer's earth terminal 		<p>Requirements</p> <ul style="list-style-type: none"> • Bridge N-PE required on backup supply. • Four-pole change-over switch required.
<p>Key: CB circuit-breaker DB distribution board E/L earth leakage GEN backup generator UPS battery backup supply</p>		

Annex B

Table B.3 — Embedded generator without backup supply

1 Supply earthing system	2 Wiring diagram	3 Earthing comments
<p>TN-S</p> <ul style="list-style-type: none"> • Five-wire supply. • Consumer's earth electrode not required. • No N-PE bridge on consumer's earth terminal 		<p>Requirements</p> <ul style="list-style-type: none"> • EG on E/L device <p>Options</p> <ul style="list-style-type: none"> • EG earth electrode desired
<p>TN-C-S</p> <ul style="list-style-type: none"> • Four-wire supply. • Consumer's earth electrode not required. • Bridge N-PE required on consumer's earth terminal 		<p>Requirements</p> <ul style="list-style-type: none"> • EG on E/L device <p>Options</p> <ul style="list-style-type: none"> • EG earth electrode desired
<p>TT</p> <ul style="list-style-type: none"> • Four-wire supply. • Consumer's earth electrode required. • No N-PE bridge on consumer's earth terminal 		<p>Requirements</p> <ul style="list-style-type: none"> • EG on E/L device
<p>Key: CB circuit-breaker DB distribution board E/L earth leakage GEN backup generator EG embedded generator UPS battery backup supply</p>		

Annex B

Table B.4 — Backup supply with a.c. coupled embedded generator

1 Supply earthing system	2 Wiring diagram	3 Earthing comments
<p>TN-S</p> <ul style="list-style-type: none"> • Five-wire supply. • Consumer's earth electrode not required. • No N-PE bridge on consumer's earth terminal 		<p>Requirements</p> <ul style="list-style-type: none"> • EG on E/L device • Backup supply earth electrode required • Bridge N-PE required on backup supply. • Change-over switch 1 required to be four-pole • Change-over switch 2 required to be four-pole.
<p>TN-C-S</p> <ul style="list-style-type: none"> • Four-wire supply. • Consumer's earth electrode not required. • Bridge N-PE required on consumer's earth terminal 		<p>Requirements</p> <ul style="list-style-type: none"> • EG on E/L device • Backup supply earth electrode required <p>Options</p> <ul style="list-style-type: none"> • If bridged N-PE on backup supply, then change-over switch 1 required to be four-pole. • If open N-PE on backup supply, then change-over switch 1 required to be three-pole. • Change-over switch 2 required to be four-pole.
<p>TT</p> <ul style="list-style-type: none"> • Four-wire supply. • Consumer's earth electrode required. • No N-PE bridge on consumer's earth terminal 		<p>Requirements</p> <ul style="list-style-type: none"> • EG on E/L device • Bridge N-PE required on backup supply. • Change-over switch 1 required to be four-pole • Change-over switch 2 required to be four-pole.
<p>Key: CB circuit-breaker DB distribution board E/L earth leakage GEN backup generator EG embedded generator UPS battery backup supply</p>		

Annex B

Table B.5 — Backup supply with or without d.c. coupled embedded generator

1 Supply earthing system	2 Wiring diagram	3 Earthing comments
<p>TN-S</p> <ul style="list-style-type: none"> • Five-wire supply. • Consumer's earth electrode not required. • No N-PE bridge on consumer's earth terminal 		<p>Requirements</p> <ul style="list-style-type: none"> • If bridged N-PE on backup supply, then four-pole change-over switch required. • If open N-PE on backup supply, then three-pole change-over switch required
<p>TN-C-S</p> <ul style="list-style-type: none"> • Four-wire supply. • Consumer's earth electrode not required. • Bridge N-PE required on consumer's earth terminal 		<p>Options</p> <ul style="list-style-type: none"> • If bridged N-PE on backup supply, then four-pole change-over switch required. • If open N-PE on backup supply, then three-pole change-over switch required.
<p>TT</p> <ul style="list-style-type: none"> • Four-wire supply. • Consumer's earth electrode required. • No N-PE bridge on consumer's earth terminal 		<p>Requirements</p> <ul style="list-style-type: none"> • Bridged N-PE required on backup supply. • Four-pole change-over switch required.
<p>Key: CB circuit-breaker DB distribution board GFDI ground fault detector interrupter GEN backup generator EG embedded generator UPS battery backup supply</p>		

Annex B (concluded)

B.3 Rules of thumb established for embedded generation and backup systems

B.3.1 General

Earthing and wiring guidelines were developed as a result of the above rigorous analysis. See tables B.2 to B.5.

B.3.2 Earth electrode

B.3.2.1 All backup systems shall have an own earth electrode connected to the consumer's earth terminal and shall comply with 7.12.3.1.1 in SANS 10142-1:2009.

B.3.2.2 Embedded generators need not have their own earth electrode in accordance with SANS 10142-1, but an own earth electrode is preferred.

B.3.3 N-PE bridge on consumer's earth terminal

B.3.3.1 The TN-C-S system shall be bridged between N and PE on the consumer's earth terminal in the installation on the supply side of the point of control.

B.3.3.2 TN-S and TT systems shall be un-bridged (as normal practice).

NOTE This is to comply with standard installation requirements for safety.

B.3.4 N-PE bridge on backup supply

B.3.4.1 TN-S and TT systems shall be bridged.

B.3.4.2 The TN-C-S may be either bridged or un-bridged. This, however, impacts on change-over switch requirements.

B.3.5 Change-over switch No. 1 (between main supply and backup supply)

B.3.5.1 In the case of backup systems WITHOUT an internal N-PE bridge (i.e. where N and PE are isolated), the following is required:

- a) for a three-phase system: a three-pole change-over switch with common neutral bar; and
- b) for a single-phase system: a single-pole change-over switch with common neutral bar.

B.3.5.2 In the case of backup systems WITH an internal N-PE bridge, the following is required:

- a) for a three-phase system: a four-pole change-over switch including neutral, or a three-pole with overlapping neutral; and
- b) for a single-phase system: a two-pole change-over switch including neutral, or a single pole with overlapping neutral.

B.3.5.3 Manual change-over switches shall be three position switches, i.e. break-before-make.

B.3.6 Change-over switch No. 2 (between a.c. coupled embedded generator and backup supply)

B.3.6.1 In the case of a three-phase system, there shall be a four-pole change-over switch including neutral, or a three-pole with overlapping neutral.

B.3.6.2 In the case of a single-phase system, there shall be a two-pole change-over switch including neutral, or a single pole with overlapping neutral.

Bibliography

Standards

AS 4777.3, *Grid connection of energy systems via inverters – Part 3: Grid protection requirements.*

Eskom standard 34-1765, *Distribution standard for the interconnection of embedded generation.*
(To be incorporated into NRS 097-1.)

IEC 60364-1, *Low-voltage electrical installations – Part 1: Fundamental principles, assessment of general characteristics, definitions.*

IEC 60898-1, *Electrical accessories – Circuit-breakers for overcurrent protection for household and similar installations – Part 1: Circuit-breakers for a.c. operation.*

IEC 60898-2, *Electrical accessories – Circuit-breakers for overcurrent protection for household and similar installations – Part 2: Circuit-breakers for a.c. and d.c. operation.*

IEC/TR 61000-3-15, *Electromagnetic compatibility (EMC) – Part 3-15: Limits – Assessment of low frequency electromagnetic immunity and emission requirements for dispersed generation systems in LV network.*

IEEE 1547, *Standard for interconnecting distributed resources with electric power systems.*

NRS 098, *Guidelines for the installation and safe use of portable generators on utilities' networks.*

SANS 10199, *The design and installation of earth electrodes.*

SANS 61000-3-2/IEC 61000-3-2, *Electromagnetic compatibility (EMC) – Part 3-2: Limits – Limits for harmonic current emissions (equipment input current ≤ 16 A per phase).*

SANS 61000-3-3/IEC 61000-3-3, *Electromagnetic compatibility (EMC) – Part 3-3: Limits – Limitation of voltage changes, voltage fluctuations and flicker in public low-voltage supply systems, for equipment with rated current ≤ 16 A per phase and not subject to conditional connection.*

SANS 61000-3-4/IEC 61000-3-4, *Electromagnetic compatibility (EMC) – Part 3-4: Limits – Limitation of emission of harmonic currents in low-voltage power supply systems for equipment with rated current greater than 16 A.*

SANS 61000-3-5/IEC 61000-3-5, *Electromagnetic compatibility (EMC) – Part 3-5: Limits – Limitation of voltage fluctuations and flicker in low-voltage power supply systems for equipment with rated current greater than 75 A.*

SANS 61000-3-11/IEC 61000-3-11, *Electromagnetic compatibility (EMC) – Part 3-11: Limits – Limitation of voltage changes, voltage fluctuations and flicker in public low-voltage supply systems – Equipment with rated current ≤ 75 A and subject to conditional connection.*

SANS 61000-3-12/IEC 61000-3-12, *Electromagnetic compatibility (EMC) – Part 3-12: Limits – Limits for harmonic currents produced by equipment connected to public low-voltage systems with input current > 16 A and ≤ 75 A per phase.*

VDE 0126-1-1, *Automatic disconnection device between a generator and the public low-voltage grid.*

Bibliography

(concluded)

Other publications

Department of Minerals and Energy. *Tradable renewable energy certificate system feasibility study*. March 2007. Pretoria.

EA Engineering Recommendation G59/1, Amendment 1-June 2008, *Recommendation for the connection of embedded generating plant to the public distribution system*.

German Solar Energy Society. *Planning and Installing Photovoltaic Systems – A guide for installers, architects and engineers*. Ecofys 2005, Berlin.

International Energy Agency. IEA Task 5. *Grid interconnection of building integrated and other dispersed photovoltaic power systems – Report IEA PVPS T5-09, Evaluation of islanding detection methods for photovoltaic utility-interactive power systems*. March 2002.

REN21. 2008. *Renewables 2007 Global Status Report*. (Paris: REN21 Secretariat and Washington, DC: WorldWatch Institute). Copyright © 2008 Deutsche Gesellschaft für Technische Zusammenarbeit (GTZ) GmbH.

Seltmann, T, *Photovoltaik: Strom ohne Ende – Netzgekoppelte Solarstromanlagen optimal bauen und nutzen*, Solarpraxis AG, Berlin.

South African Distribution Network Code, Version 5.1. Approved September 2007.

SABS – Standards Division

The objective of the SABS Standards Division is to develop, promote and maintain South African National Standards. This objective is incorporated in the Standards Act, 2008 (Act No. 8 of 2008).

Amendments and Revisions

South African National Standards are updated by amendment or revision. Users of South African National Standards should ensure that they possess the latest amendments or editions.

The SABS continuously strives to improve the quality of its products and services and would therefore be grateful if anyone finding an inaccuracy or ambiguity while using this standard would inform the secretary of the technical committee responsible, the identity of which can be found in the foreword.

Tel: +27 (0) 12 428 6666 Fax: +27 (0) 12 428 6928

The SABS offers an individual notification service, which ensures that subscribers automatically receive notification regarding amendments and revisions to South African National Standards.

Tel: +27 (0) 12 428 6883 Fax: +27 (0) 12 428 6928 E-mail: sales@sabs.co.za

Buying Standards

Contact the Sales Office for South African and international standards, which are available in both electronic and hardcopy format.

Tel: +27 (0) 12 428 6883 Fax: +27 (0) 12 428 6928 E-mail: sales@sabs.co.za

South African National Standards are also available online from the SABS website <http://www.sabs.co.za>

Information on Standards

The Standards Information Centre provides a wide range of standards-related information on both national and international standards, and is the official WTO/TBT enquiry point for South Africa. The Centre also offers an individual updating service called INFOPLUS, which ensures that subscribers automatically receive notification regarding amendments to, and revisions of, international standards.

Tel: +27 (0) 12 428 6666 Fax: +27 (0) 12 428 6928 E-mail: info@sabs.co.za

Copyright

The copyright in a South African National Standard or any other publication published by the SABS Standards Division vests in the SABS. Unless exemption has been granted, no extract may be reproduced, stored in a retrieval system or transmitted in any form or by any means without prior written permission from the SABS Standards Division. This does not preclude the free use, in the course of implementing the standard, of necessary details such as symbols, and size, type or grade designations. If these details are to be used for any purpose other than implementation, prior written permission must be obtained.

Details and advice can be obtained from the Senior Manager.

Tel: +27 (0) 12 428 6666 Fax: +27 (0) 12 428 6928 E-mail: info@sabs.co.za